

Compact Crawler Excavator

OPERATING WEIGHT	4,300 – 4,455 lbs (1,950 – 2,020 kg)
NET ENGINE POWER	18 hp (13.3 kW)
MAX DIG DEPTH	8' 2" (2.5 m)
MAX REACH	14' 4" (4.4 m)



Unit shown with optional hydraulic hammer.

COMPACT CRAWLER EXCAVATOR
TC20

Operating Data, Standard Equipment

Operating weight (rubber crawlers)	4,300 lbs (1,950 kg)
Operating weight (steel crawlers)	4,455 lbs (2,020 kg)
Overall length (travel position)	8' 10" (2.7 m)
Overall height (travel position)	8' 10" (2.7 m)
Total length (trailer transport position)	13' 9" (4.2 m)
Total height (top of cab)	7' 5" (2.3 m)
Total width (crawlers retracted)	3' 3" (1.0 m)
Uppercarriage tailswing	3' 8" (1.2 m)
Working envelope, 180°	8' 4" (2.6 m)
Working envelope, 360°	9' 2" (2.8 m)
Ground clearance	7" (170 mm)
Bucket digging force (SAE J 1179)*	3,535 lbs (15,700 N)
Stick digging force (SAE J 1179)*	2,185 lbs (9,700 N)
Ground pressure (rubber crawlers)	4.3 psi (0.30 daN/cm ²)
Ground pressure (steel crawlers)	4.4 psi (0.31 daN/cm ²)

*Standard equipment, may vary with different bucket and/or dipperstick.



Specifications

Engine

Manufacturer, model	Mitsubishi, L3E-W 262 KL
Type	3-cylinder diesel engine
Combustion	4-stroke cycle, swirl chamber injection
Displacement	58 in ³ (952 cm ³)
Net power rating at 2,400 rpm (SAE J 1349)	18 hp (13.3 kW)
Torque @ 2,000 rpm	439.6 lbf (54 Nm)
Cooling system	Water

Electrical System

Nominal voltage	12 V
Battery	12 V / 74 Ah

Power Transmission

Hydrostatic drive with axial piston motor and reduction gear, fully enclosed. Brake valve for downhill drive.	
Travel speed, forward/reverse	0–1.7/0–2.8 mph (0–2.7/4.5 km/h)
Gradeability	60%
Drawbar pull (1st/2nd speed range)	3,375/1,643 lbs (1,500/730 daN)
Travel motion alarm (acoustic signal) as standard.	

Undercarriage

Maintenance-free crawler-type undercarriage. Idler suspension with hydraulic crawler tensioning. Hydraulically retractable / extendable undercarriage provided as standard. Crawler adjustment by means of ball valve, dozer blade can be actuated from operator's seat.	
Range of adjustment (outer edge of crawlers)	39"-53" (990-1,340 mm)
Rubber crawlers / steel crawlers	9" / 9" (230/230 mm)
Total length (sprocket-idler)	3' 7" (1.1 m)
Total length (undercarriage)	4' 9" (1.5 m)

Dozer Blade

Independent of drive train, sensitive control via hand lever.	
Width x height	53" x 9" (1,340 x 235 mm)
Cut below ground	6" (160 mm)
Lift above ground	8" (200 mm)
Slope angle	25°

Steering

Independent control of tracks via hand controls or foot pedals.

Swing System

Hydrostatic drive, also acting as low-maintenance brake. Additional brake to be operated by multi-function handle (push-button), also acts when engine is shut off. Internally toothed ring gear.	
Swing speed	0 – 10 rpm

Hydraulic System

Dual fixed displacement pump with cover switch. Load-independent flow division (LUDV) for all work functions and travel drive, 3 simultaneous movements possible.	
Working pressure	2,600 psi (160 bar)
Pump capacity	9 gpm + 5 gpm (33.5 Lpm + 19.2 Lpm)
Tank-immersed return filter with electric contamination indicator. Block hydraulic oil radiator provided as standard. Boom, dipperstick and articulated cylinders with end-position damping on both sides, bucket retract function with one-side end-position damping.	
Standard control circuit for work attachments.	
Hydraulic power	8.7 gpm (33 Lpm) @ 1,450 psi (120 bar) 8 gpm (30 Lpm) @ 2,030 psi (140 bar)
Open return as standard. All functions can be activated proportionally. Two servo-assisted four-way control levers for excavator operations. Safety cut-off of all functions as soon as driver leaves cab.	

Knickmatik®

Boom offset to provide lateral parallel adjustment at full digging depth.	
Angle of artic./ lateral adjustment left	60°/16.5" (60°/420 mm)
Angle of artic./ lateral adjustment right	60°/21.6" (60°/550 mm)

Cab

Spacious, sound-insulated, full-vision steel cab with two equally large doors. TOPS certified. Safety glass windows, thermo windows tinted in green. Skylight thermo window. Front window supported by pneumatic springs, lockable in place for ventilation and slideable under cab roof. Windshield washer system. Glove box. Instrument panel to the right of the operator's seat with visual and acoustic warning device. Left-hand outside rear-view mirror. Cab heating with windshield defroster through coolant heat exchanger and 2-speed fan, ventilating mode in summer. Fabric-covered, hydraulically cushioned operator's seat with height-adjustable armrests, height, tilt and weight adjustments, lap belt.	
Working floodlight Halogen H-3.	
Noise emission ambience LWA / Noise emission cab LpA	95/78 dB (A)
Measured in dynamic measuring cycle (EEC-directive 2000/A4/E6).	

Fluid Capacities

Fuel tank	7.9 gal (30 L)
Hydraulic system (tank 6.6 gal / 25 L)	9 gal (35 L)

Working Ranges & Dimensions

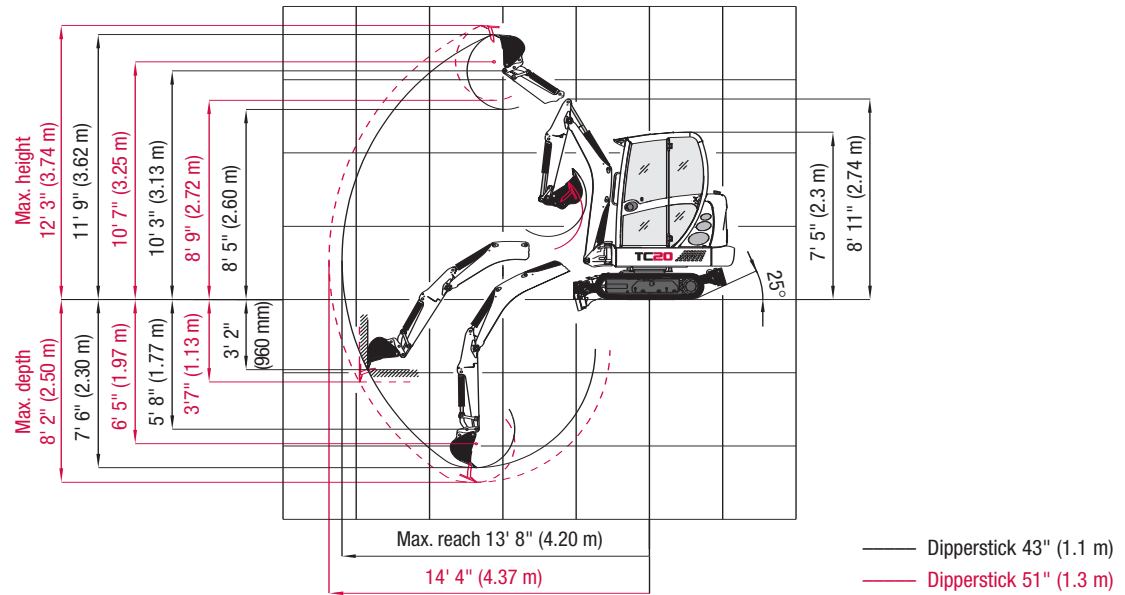

Lifting Capacities with 51" (1.3 m) Dipperstick

ENGLISH Measurements Unit: x 1,000 lbs		Load radius from the center of the ring gear																UE = Undercarriage extended	UR = Undercarriage retracted				
Bucket hinge pin height		4' 11"				6' 7"				8' 2"				9' 10"				11' 8"					
Dipperstick 51"		UE		UR		UE		UR		UE		UR		UE		UR		UE		UR			
		End	Side	End	Side	End	Side	End	Side	End	Side	End	Side	End	Side	End	Side	End	Side	End	Side		
6' 7"	Supported by blade	-	-	-	-	-	-	-	-	0.86	0.99	0.86	0.71	0.82	0.77	0.82	0.55	0.57	0.55	0.57	0.44		
	Traveling	-	-	-	-	-	-	-	-	0.84	0.95	0.84	0.68	0.79	0.71	0.79	0.53	0.53	0.53	0.53	0.44		
3' 3"	Supported by blade	-	-	-	-	1.50	1.15	1.50	0.97	1.06	0.97	1.06	0.68	0.84	0.79	0.84	0.53	0.66	0.64	0.66	0.42		
	Traveling	-	-	-	-	1.48	1.10	1.48	0.95	1.01	0.93	1.01	0.66	0.82	0.75	0.82	0.51	0.64	0.57	0.64	0.42		
0"	Supported by blade	-	-	-	-	1.54	1.28	1.54	0.88	1.10	0.95	1.10	0.64	0.82	0.73	0.82	0.51	0.62	0.62	0.62	0.40		
	Traveling	-	-	-	-	1.30	1.23	1.30	0.84	0.95	0.88	0.95	0.60	0.79	0.68	0.79	0.46	0.60	0.60	0.60	0.37		
-2' 6"	Supported by blade	2.20	1.65	2.20	1.23	1.21	1.41	1.21	0.86	0.86	0.73	0.86	0.64	0.66	0.55	0.66	0.51	0.40	0.40	0.40	0.40		
	Traveling	2.16	1.63	2.16	1.17	1.19	1.37	1.19	0.82	0.84	0.68	0.84	0.60	0.66	0.51	0.66	0.46	0.40	0.40	0.40	0.40		

METRIC Measurements Unit: Metric tons		Load radius from the center of the ring gear																				
Bucket hinge pin height		1.5 m				2.0 m				2.5 m				3.0 m				3.5 m				
Dipperstick 1,300 mm		UE		UR		UE		UR		UE		UR		UE		UR		UE		UR		
		End	Side	End	Side	End	Side	End	Side	End	Side	End	Side	End	Side	End	Side	End	Side	End	Side	
2 m	Supported by blade	-	-	-	-	-	-	-	-	0.39	0.45	0.39	0.32	0.37	0.35	0.37	0.25	0.26	0.25	0.26	0.20	
	Traveling	-	-	-	-	-	-	-	-	0.38	0.43	0.38	0.31	0.36	0.32	0.36	0.24	0.24	0.24	0.24	0.20	
1 m	Supported by blade	-	-	-	-	0.68	0.52	0.68	0.44	0.48	0.44	0.48	0.31	0.38	0.36	0.38	0.24	0.30	0.29	0.30	0.19	
	T	-	-	-	-	0.67	0.50	0.67	0.43	0.46	0.42	0.46	0.30	0.37	0.34	0.37	0.23	0.29	0.26	0.29	0.19	
0 m	Supported by blade	-	-	-	-	0.70	0.58	0.70	0.40	0.50	0.43	0.50	0.29	0.37	0.33	0.37	0.23	0.28	0.28	0.28	0.18	
	Traveling	-	-	-	-	0.59	0.56	0.59	0.38	0.43	0.40	0.43	0.27	0.36	0.31	0.36	0.21	0.27	0.27	0.27	0.17	
-0.75 m	Supported by blade	1.00	0.75	1.00	0.56	0.55	0.64	0.55	0.39	0.39	0.33	0.39	0.29	0.30	0.25	0.30	0.23	0.18	0.18	0.18	0.18	
	Traveling	0.98	0.74	0.98	0.53	0.54	0.62	0.54	0.37	0.38	0.31	0.38	0.27	0.30	0.23	0.30	0.21	0.18	0.18	0.18	0.18	

The above loads (all values in lbs x 1,000 resp. metric tons) are in compliance with SAE J 1097. They do not exceed 87% of hydraulic lifting capacity or 75% of tipping capacity. All values were determined with quick-attach system but without bucket. In case of mounted-on work attachments, the deadweights of the work attachments must be deducted from the permissible payloads. Work equipment: Rubber crawlers, undercarriage extended, dipperstick 43" (1.1 m).

Compact Crawler Excavator TC20

Working Envelope / Top View

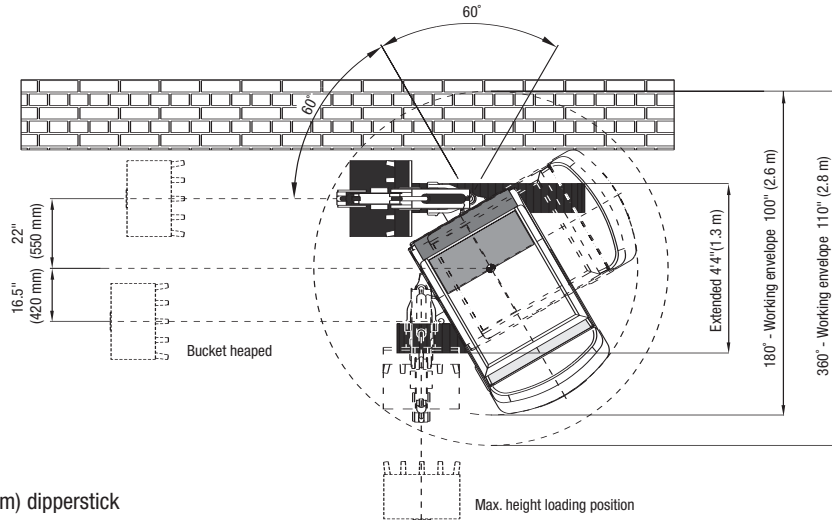

Work equipment: 43" (1.1 m) dipperstick

Attachments / Accessories

Optional Accessories

Mechanical quick-coupler system for work tools (QMH)	
Canopy (weight reduction 220 lbs / 100 kg)	
Luxury operator's seat, height-adjustable, with extra-high back rest, progressively adjustable to operator's weight, seating with tilt and lengthwise adjustment. Upward folding, tilt-adjustable comfort armrests.	
Dipperstick	43" (1.1 m)
Cab-mounted working floodlight (front and rear)	
Boom-mounted working floodlight	
Yellow beacon	
Crane lifting beam	
Quick change adapter for hydraulic hammer	
Filling with biodegradable hydraulic oil, ester-based, VI 68	
Immobilizer (anti-theft device)	

Bucket Options

Pin-on Style / Quick Coupler	Capacity cu. ft.	(Liters)
10" (250 mm) H.D. Bucket	1.38	40
12" (300 mm) H.D. Bucket	2.03	58
16" (400 mm) H.D. Bucket	2.32	65
18" (450 mm) H.D. Bucket	2.65	75
20" (500 mm) H.D. Bucket	3.27	93
24" (600 mm) H.D. Bucket	4.24	120
36" (900 mm) Ditch-cleaning Bucket	5.18	147

Hydraulic Hammer

Sound-insulated. Tools: Moil point or chisel point



Terex Construction Americas

8800 Rostin Road
Southaven, MS 38671
USA

TEL 662-393-1800
SALES 866-837-3923
PARTS & TECH SUPPORT 888-201-6008
FAX 662-393-1700
EMAIL sales@terexca.com
WEB terexca.com

For more information, product demonstration, or details on purchase, lease and rental plans, please contact your local Terex Distributor.