



TEREX

TXC 340LC-1

Hydraulic Excavator

OPERATING WEIGHT	76,500 lbs (34,700 kg)
NET ENGINE POWER	247 hp (184 kW) @ 1,900 rpm
MAX DIG DEPTH	25' 2" (7,670 mm)
MAX REACH	36' 10" (11,230 mm)



HYDRAULIC EXCAVATOR
TXC 340LC-1

FEATURES

- Powerful, quiet, fuel efficient, turbocharged USA EPA Tier 2 compliant diesel engine maximizes power output and utilization
- e-EPOS System uses variable displacement piston pumps ensuring high efficiency and lower fuel consumption
- Swing anti-rebound valve assures quick, precise, and smooth directional stops during dumping or cradling
- Exceptional bucket break-out and radial tooth forces for toughest digging
- Spacious, comfortable cab provides excellent visibility and ergonomic operating environment
- Advanced graphic display LCD information monitor panel makes troubleshooting easier, simplifies machine performance record keeping
- Standard equipped 3-switch joystick control and hydraulic piping to boom base facilitate installation of most attachments
- Equipped to maximize operator comfort, efficiency and performance
- More standard features to make this TEREX hydraulic excavator the most productive ever

Specifications

Engine	
Model	DAEWOO DE12TIS
Type	Water-cooled, 4-cycle, direct injection, aspiration, turbocharged, air-to-air intercooled. USA EPA Tier 2 compliant.
No. of cylinders	6
Rated flywheel horsepower	
DIN 6271, net	250 PS (184 kW) @ 1,900 rpm
SAE J1349, net	247 HP (184 kW) @ 1,900 rpm
Piston displacement	675 cu. in. (11,051 cc)
Maximum torque	781 lbf.ft. (1059 Nm) @ 1,400 rpm
Bore and stroke	4.8" x 6.1" (123 mm x 155 mm)
Starting system	24V electric motor
Batteries	2 x 12V x 150 AH

Hydraulic System	
e-EPOS (Electronic Power Optimizing System) allows the operator to maximize work efficiency over a full range of operating conditions and to minimize fuel consumption.	
Hydraulic system assures fully independent and combined operations.	
Automatic 2 speed travel system for high traction force and travel speed.	
Cross-sensing and fuel saving pump system.	
Auto idle system.	
2-Working / 2-power mode selection system.	
Computer aided engine-pump control.	
Main pumps	2 variable displacement axial piston pumps.
Max. oil flow	2 x 70.3 gpm (2 x 266 L/min)
Pilot pump	Gear pump
Max. oil flow	7.5 gpm (28.5 L/min)
Swing motor	
Relief valve	3,780 psi (266 bar)
Main relief valves	
Boom/Stick/Bucket	Normal: 4,690 psi (324 bar) Power Boost: 4,970 psi (343 bar)
Travel circuit	4,690 psi (324 bar)

Hydraulic Cylinders			
High-strength piston rods and tubes are used. Cylinder cushion mechanism is provided for all cylinders to minimize shock during operation and extend cylinder component life.			
Cylinders	Qty	Bore x Rod dia x Stroke	
Boom	2	5.9" x 3.9" x 56.7" (150 x 100 x 1,440 mm)	
Stick	1	6.7" x 4.5" x 71.3" (170 x 115 x 1,812 mm)	
Bucket	1	5.9" x 3.9" x 51.2" (150 x 100 x 1,300 mm)	

Superstructure Revolving Frame
Deep full-reinforced box section constructed of heavy gauge steel plates.

Operator's Cab
Cab is independent and roomy. 4 side safety glass windows give excellent visibility. Front window slides up and stores in the roof and side window can be opened for ventilation. Fully adjustable suspension seat. Air conditioner. ISO standard cab.

Noise Levels (dynamic value)	
LwA External noise	
Guaranteed Sound Power Level	107 dB(A) (2,000/14/EC)
Measured Sound Power Level	106 dB(A) (2,000/14/EC)
LpA Operator Noise	76 dB(A) (ISO 6396)

Controls - 2 Implement Levers
Pilot pressure control type. Right lever is boom and bucket control, left lever for swing and stick control.

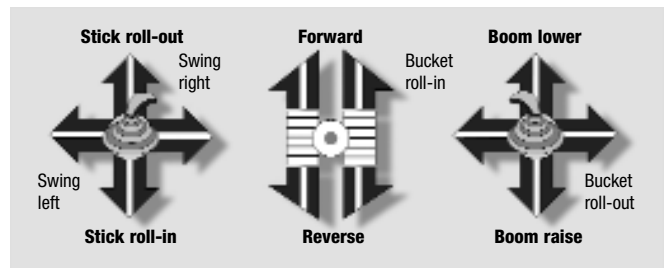

2 Travel Pedal with Levers
Pilot pressure control type. Independent drive at each track allows counter-rotation of the tracks. Levers are detachable.

Swing Mechanism	
High-torque, axial piston motor with planetary reduction gear in oil bath. Swing assembly is single row, shear type ball bearing with induction-hardened internal gear. Internal gear and pinion gear immersed in lubricant. Swing parking brake is spring-set, hydraulic-released disc type. A two position swing lock secures the superstructure for transportation.	
Swing speed	0 to 8.9 rpm
Rear swing radius	11' 6" (3,500 mm)

Drive	
Each track is driven by an independent, high-torque, axial piston motor through planetary reduction gearing. Two levers or foot pedal control provide smooth travel or counter-rotation upon demand.	
Travel speed (High/Low)	2.9/1.9 mph (4.6/3.1 km/h)
Maximum traction force	61,300 lbf (273 kN)
Gradeability	35° (70%) continuous

Brakes	
Two oil disc brakes outboard mounted on final drive input shafts. Parking brake is spring-set, hydraulic-released disc type.	

Specifications

Undercarriage

Tractor type undercarriage. Heavy-duty track frame, all welded stress-relieved structure. The highest grade materials are used for toughness. Side frames are welded, securely and rigidly, to the track frame. Lifetime-lubricated track rollers, idlers and sprockets with floating seals reduce field service requirements. Track shoes of induction-hardened rolled alloy with triple grousers ensure long life under the harshest applications. Specially heat-treated connecting pins reduce wear. Hydraulic track adjusters with shock-absorbing recoil springs are standard.

Number of rollers and shoes (each side) ground contact area

Upper rollers 2

(Standard Shoe)

Lower rollers 9

Track shoes 51

Overall track length 16' 3" (4,960 mm)

Weight

Equipped with 21' 3" (6.5 m) boom, 10' 5" (3.2 m) stick, and 1.93 yd³; PCSA heaped (1.48 m³) bucket.

Shoe type	Shoe width	Operating weight	Ground pressure
Triple grouser	24" (600 mm)	74,700 lb. (33,900 kg)	9.2 psi (63 kpa)
Triple grouser	28" (700 mm)	75,600 lb. (34,300 kg)	8.0 psi (55 kpa)
Triple grouser	32" (800 mm)	76,500 lb. (34,700 kg)	7.1 psi (49 kpa)
Triple Grouser	34" (850 mm)	79,900 lb. (34,900 kg)	6.7 psi (46 kpa)

Service Refill Capacities

	U.S. gal	Liters
Fuel tank	145.3	550
Cooling system	15.3	58
Lubrication	U.S. gal	Liters
Engine oil	7.3	28
Swing drive (each)	1.6	6
Final drive (each)	1.4	5.3
Hydraulic system	121.5	460
Hydraulic tank	55.5	210

Buckets

Capacity PCSA heaped	Width without side cutters	Width with side cutters	Weight	Stick Recommendation	
				10' 6" (3.2 m)	13' 11" (4.0 m)
1.63 yd ³ (1.25 m ³)	48" (1,228 mm)	50" (1,273 mm)	2,720 lb. (1,233 kg)	A	B
1.93 yd ³ (1.48 m ³)	56" (1,410 mm)	57" (1,456 mm)	2,955 lb. (1,340 kg)	B	B
2.10 yd ³ (1.61 m ³)	59" (1,500 mm)	61" (1,546 mm)	3,085 lb. (1,399 kg)	B	B
2.39 yd ³ (1.83 m ³)	66" (1,678 mm)	68" (1,723 mm)	3,340 lb. (1,514 kg)	B	C

- A. Suitable for materials with density of 3,370 lb./cu.yd. (2,000 kg/m³) or less
 B. Suitable for materials with density of 2,700 lb./cu.yd. (1,600 kg/m³) or less
 C. Suitable for materials with density of 1,850 lb./cu.yd. (1,100 kg/m³) or less

Standard Equipment

Hydraulic System

- Boom and stick flow regeneration
- Boom and stick holding valves
- Swing anti-rebound valves
- Spare ports (valve)
- One-touch power boost

Cab and Interior

- All weather sound suppressed cab with suspension type mounts
- Air conditioner (heavy duty) and heater/ defroster
- Adjustable suspension seat with head rest and adjustable arm rest
- Pull-up type front window and removable lower front window with storage brackets in cab
- Roof hatch/cover
- Cab light
- Intermittent windshield wiper
- Cigar lighter and ashtray
- Cup holder
- Hot and cold storage container
- Graphic LCD display monitor
- Fuel consumption controller
- AM/FM Radio and cassette player
- Remote radio ON/OFF switch
- 12V spare power socket
- Serial communication port for laptop PC interface
- Joystick levers with 3 switches

Other

- Large handrails and steps
- Punched grid-type metal anti-slip upperstructure plates
- Seat belt
- Sun roof (hatch)
- Hydraulic safety lock lever
- Safety glass
- Manual hammer mounted in cab for emergency use
- Right and left rearview mirrors
- Travel alarm
- Heavy-duty fan guard
- Dual element air cleaner
- Pre-cleaner
- Water separator
- Double fuel filter
- Radiator dust screen
- Engine overheat prevention system
- Engine restart prevention system
- Self-diagnostic system
- Heavy-duty alternator (24V, 80 amps)
- Electric horn
- Halogen working lights (frame mounted 2, boom mounted 2)
- Hydraulic track adjuster
- Sealed and greased track links
- Track guards

Optional Equipment

- Sun visor
- Cab top/front guard (ISO 10262, FOGS standard)
- Rotating beacon
- Piping for hammer (one way)
- Piping for optional implement rotation
- Additional work lights on the cab (2 front lamps, 4 front and 2 rear lamps)
- Electric fuel supply pump

Hydraulic Excavator TXC 340LC-1

Dimensions: 21' 4" (6.5 m) Boom, 10' 6" (3.2 m) Stick, 24" (600 mm) Shoe

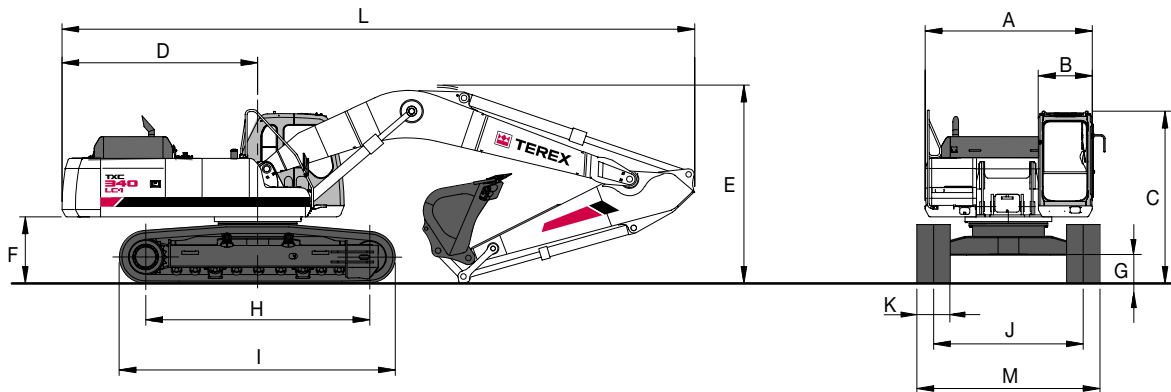

Dimensions

A Overall width of upperstructure	9' 9" (2,960 mm)
B Overall width of cab	3' 2" (960 mm)
C Overall height of cab	10' 1" (3,065 mm)
D Tail swing radius	10' 6" (3,200 mm)
E Overall height	11' 1" (3,365 mm)
F Clearance under counterweight	3' 10" (1,175 mm)
G Ground clearance	20" (500 mm)
H Idler to sprocket distance	13' 2" (4,010 mm)
I Track length	16' 2" (4,930 mm)
J Track gauge (Standard Track)	8' 6" (2,600 mm)
J1 Track gauge (Narrow Track)	7' 10" (2,400 mm)
K Track shoe width	24" (600 mm)
L Overall length	34' 10" (10,620 mm)
M Overall track width with 24" (600 mm) shoe	10' 6" (3,200 mm)

Digging Forces (Maximum radial tooth forces)

Stick	10' 6" (3.2 m)	13' 1" (4.0 m)
Bucket digging force*	48,000 lbf (213 kN)	48,000 lbf (213 kN)
Stick digging force*	38,400 lbf (170 kN)	32,900 lbf (146 kN)

*At power boost

Working Ranges

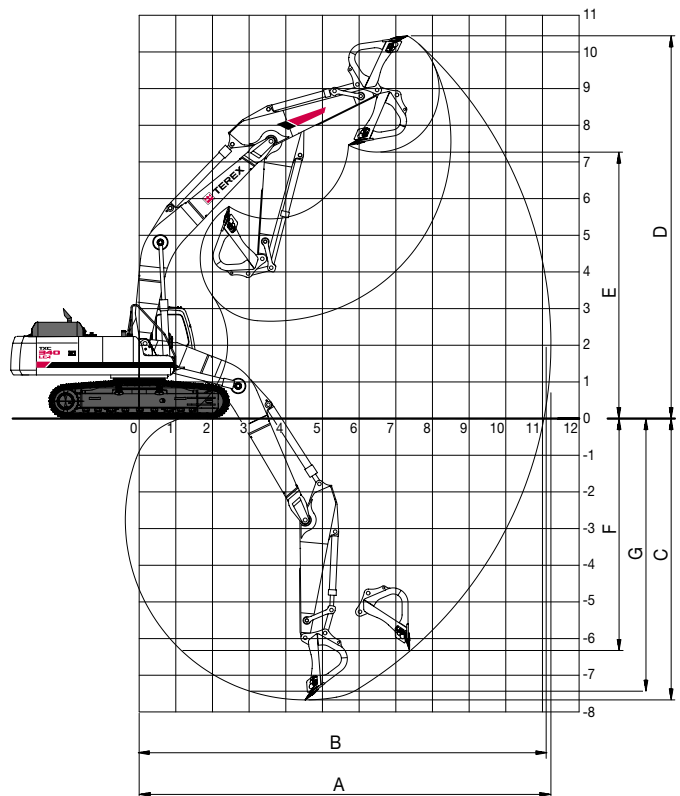

Boom Length: 21' 4" (6.5 m)

Stick length	10' 6" (3.2 m)	13' 1" (4.0 m)
A. Max. digging reach	36' 10" (11,230 mm)	39' 4" (11,990 mm)
B. Max. digging reach at ground level	36' 3" (11,040 mm)	38' 9" (11,810 mm)
C. Max. digging depth	25' 2" (7,670 mm)	27' 10" (8,480 mm)
D. Max. digging height	34' 3" (10,440 mm)	35' 6" (10,820 mm)
E. Max. dumping height	23' 10" (7,270 mm)	25' 1" (7,640 mm)
F. Max. vertical wall digging depth	20' 4" (6,200 mm)	22' 11" (6,990 mm)
G. Max. digging depth (8' level)	24' 8" (7,510 mm)	27' 4" (8,340 mm)



Lifting Capacities

Boom: 21' 4" Stick: 10' 6" Bucket: PCSA 1.93 yd ³ Shoe: 32" Weight: 76,910 lbs.													
Reach													unit: 1000 lb.
Height	10ft F	10ft S	15ft F	15ft S	20ft F	20ft S	25ft F	25ft S	30ft F	30ft S	Max. F	Max. S	Reach (ft)
25 ft							*13.50	*13.50			*13.53	*13.53	@25.93
20 ft							*13.92	*13.92			*13.70	11.58	@28.86
15 ft*					17.18	*17.18	*15.33	14.56	*14.39	10.62	*14.33	10.18	@30.70
10 ft	*23.59	*23.59	*28.02	*28.02	*20.78	19.95	*17.24	14.03	*15.29	10.36	14.60	9.44	@31.64
5 ft			*34.33	29.38	*24.20	19.00	*19.17	13.51	15.67	10.09	14.28	9.17	@31.77
0 ft	*18.78	*18.78	*37.54	28.38	*26.57	18.33	20.50	13.11	15.44	9.88	14.61	9.34	@31.08
-5 ft	*29.55	*29.55	*37.96	28.07	*27.47	18.01	20.26	12.89			15.71	10.03	@29.53
-10 ft	*42.81	*42.81	*36.11	28.18	*26.66	17.99	20.27	12.90			18.09	11.55	@26.97
-15 ft	*44.45	*44.45	*31.69	28.66	*23.51	18.30					*19.42	14.86	@23.04
-20 ft	*31.35	*31.35	*22.72	*22.72							*19.97	*19.97	@16.79

Boom: 21' 4" Stick: 10' 6" Bucket: PCSA 1.93 yd ³ Shoe: 34" Weight: 77,355 lbs.													
Reach													unit: 1000 lb.
Height	10ft F	10ft S	15ft F	15ft S	20ft F	20ft S	25ft F	25ft S	30ft F	30ft S	Max. F	Max. S	Reach (ft)
25 ft							*13.50	*13.50			*13.53	*13.53	@25.93
20 ft							*13.92	*13.92			*13.70	11.64	@28.86
15 ft					*17.18	*17.18	*15.33	14.64	*14.39	10.68	*14.33	10.24	@30.70
10 ft	*23.59	*23.59	*28.02	*28.02	*20.78	20.06	*17.24	14.11	*15.29	10.43	14.69	9.50	@31.64
5 ft			*34.33	29.53	*24.20	19.10	*19.17	13.59	15.76	10.15	14.38	9.23	@31.77
0 ft	*18.78	*18.78	*37.54	28.54	*26.57	18.44	20.62	13.19	15.53	9.94	14.70	9.40	@31.08
-5 ft	*29.55	*29.55	*37.96	28.22	*27.47	18.11	20.38	12.97			15.81	10.10	@29.53
-10 ft	*42.81	*42.81	*36.11	28.34	*26.66	18.10	20.39	12.98			18.20	11.62	@26.97
-15 ft	*44.45	*44.45	*31.69	28.81	*23.51	18.40					*19.42	14.95	@23.04
-20 ft	*31.35	*31.35	*22.72	*22.72							*19.97	*19.97	@16.79

Notes:

1. Ratings are based on SAE J1097
2. Load point is the hook on the back of the bucket.
3. *Rated loads are based on hydraulic capacity.
4. Rated loads do not exceed 87% of hyd. capacity or 75% of tipping capacity.

-  F = Rating over front
 S = Rating over side or 360 degree
 0 = Ground

Hydraulic Excavator TXC 340LC-1

Lifting Capacities

Boom: 21' 4" Stick: 13' 1" Bucket: PCSA 1.63 yd ³ Shoe: 32" Weight: 77,082 lbs.													
Reach													unit: 1000 lb.
Height	10ft F	10ft S	15ft F	15ft S	20ft F	20ft S	25ft F	25ft S	30ft F	30ft S	Max. F	Max. S	Reach (ft)
25 ft											*10.62	*10.62	@29.05
20 ft									*12.16	10.99	*10.67	9.89	@31.69
15 ft							*13.50	*13.50	*12.88	10.76	*11.04	8.81	@33.37
10 ft	*37.54	*37.54	*23.74	*23.74	*18.36	*18.36	*15.60	14.18	*14.02	10.43	*11.72	8.22	@34.24
5 ft	*20.51	*20.51	*31.04	29.98	*22.22	19.22	*17.81	13.58	*15.27	10.09	12.55	7.98	@34.35
0 ft	*20.12	*20.12	*35.83	28.56	*25.26	18.38	*19.67	13.08	15.36	9.80	12.76	8.08	@33.72
-5 ft	*26.71	*26.71	*37.73	27.91	*26.94	17.89	20.12	12.76	15.17	9.62	13.54	8.57	@32.30
-10 ft	*36.38	*36.38	*37.20	27.79	*27.06	17.72	19.99	12.64			15.17	9.62	@29.98
-15 ft	*49.70	*49.70	*34.27	28.05	*25.26	17.84	*19.06	12.77			*17.38	11.73	@26.51
-20 ft	*39.78	*39.78	*28.01	*28.01	*20.25	18.35					*18.38	16.68	@21.33

Boom: 21' 4" Stick: 13' 1" Bucket: PCSA 1.63 yd ³ Shoe: 34" Weight: 77,527 lbs.													
Reach													unit: 1000 lb.
Height	10ft F	10ft S	15ft F	15ft S	20ft F	20ft S	25ft F	25ft S	30ft F	30ft S	Max. F	Max. S	Reach (ft)
25 ft											*10.62	*10.62	@29.05
20 ft									*12.16	11.05	*10.67	9.95	@31.69
15 ft							*13.50	*13.50	*12.88	10.82	*11.04	8.87	@33.37
10 ft	*37.54	*37.54	*23.74	*23.74	*18.36	*18.36	*15.60	14.26	*14.02	10.50	*11.72	8.27	@34.24
5 ft	*20.51	*20.51	*31.04	30.13	*22.22	19.32	*17.81	13.66	*15.27	10.16	12.63	8.04	@34.35
0 ft	*20.12	*20.12	*35.83	28.71	*25.26	18.49	*19.67	13.16	15.46	9.87	12.85	8.14	@33.72
-5 ft	*26.71	*26.71	*37.73	28.07	*26.94	17.99	20.25	12.83	15.27	9.69	13.63	8.63	@32.30
-10 ft	*36.38	*36.38	*37.20	27.94	*27.06	17.82	20.12	12.72			15.27	9.68	@29.98
-15 ft	*49.70	*49.70	*34.27	28.21	*25.26	17.95	*19.06	12.85			*17.38	11.80	@26.51
-20 ft	*39.78	*39.78	*28.01	*28.01	*20.25	18.45					*18.38	16.78	@21.33

Notes:

1. Ratings are based on SAE J1097
2. Load point is the hook on the back of the bucket.
3. *Rated loads are based on hydraulic capacity.
4. Rated loads do not exceed 87% of hyd. capacity or 75% of tipping capacity.



F = Rating over front



S = Rating over side or 360 degree

0 = Ground



For more information, product demonstration, or details on purchase, lease and rental plans, please contact your local TEREX Distributor.

TEREX Construction Americas

8800 Rostin Road
Southaven, MS 38671
USA

TEL 662-393-1800
SALES 866-837-3923
PARTS & TECH SUPPORT 888-201-6008
FAX 662-393-1700
EMAIL sales@terexca.com
WEB terexca.com

Effective date: January 1, 2005. For further information, please contact your local distributor or the TEREX sales office listed. Continuous improvement of our products is a TEREX policy. Product specifications are subject to change without notice or obligation. The photographs and drawings in this brochure are for illustrative purposes only. Refer to the appropriate Operator's Manual for instructions on the proper use of this equipment. Failure to follow the appropriate Operator's Manual when using our equipment or to otherwise act irresponsibly may result in serious injury or death. Prices and specifications subject to change without notice. The only warranty applicable is the standard written warranty applicable to the particular product and sale. TEREX makes no other warranty, expressed or implied. Products and services listed may be trademarks, service marks or trade-names of TEREX Corporation and/or its subsidiaries in the USA and other countries and all rights are reserved. "TEREX" is a Registered Trademark of TEREX Corporation in the USA and many other countries. Copyright ©2005 TEREX Corporation
TXL 340LC-1 5K 0305B Part #109077